

Sport Bike Rearset Kit

PKT-041



Introduction:

Made in USA

This easy to install, high quality, Powerlet™ kit provides a convenient way to access the battery on most sport bikes. The operator can supply power to the battery (i.e. battery charger), draw power from the battery (i.e. heated vest), or monitor the state of charge on the battery using the Powerlet socket.

Parts List:

- 1 – Wiring harness w/15A fuse
- 1 – Mounting bracket w/socket
- 1 – 1/8" Spacer
- Ty-wrap(s)

Please read all of the instructions carefully before attempting the installation of this product. Have this kit installed by a trained technician if you are not familiar with these procedures.

Quick Start Instruction:

- STEP #1 Remove the seat.
- STEP #2 Route wires starting at the battery and finishing at the bracket.
- STEP #3 Attach the wires to the socket
- STEP #4 Mount the bracket.
- STEP #5 Attach the ty-wrap; examine your work.
- STEP #6 Test & reassemble.

Detailed Instruction:

STEP #1 – Remove the seat. See the service manual.

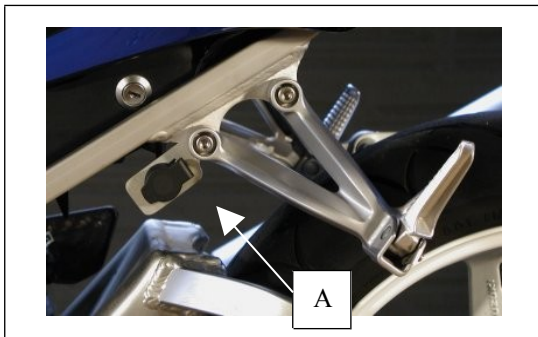

STEP #2 – Stretch out the wiring harness. Grab the socket end of the harness and start routing the harness by looping the wires down through the gap between the frame member and the battery compartment plastic [B]. Let the wire hang down by the bracket for now. Next remove the negative battery connection, followed by the positive battery connection. Slip the red wire under the red battery boot [C]. You may need to trim the red boot to accommodate the added wire. Connect the red & black wire as follows:

RED WIRE = BATTERY POSITIVE
BLACK WIRE = CHASSIS GROUND

For example, the chassis bolt [D] is shown for the Yamaha R6. If a chassis bolt is not available connect the black wire to the battery negative terminal. Tuck the fuse holder into a cavity in front of the plus terminal of the battery [C]. Do not allow the red lead between the battery plus terminal and fuse-holder to cross any metal objects[C]. Ty-wrap the fuse-holder to the nearby wiring.

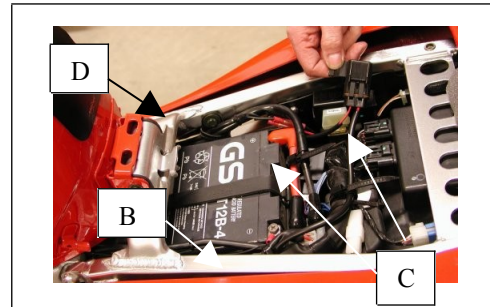

STEP #3 – Install the fuse in the fuse-holder. Next attach the spade connectors to the socket. The center terminal of the Powerlet socket is plus and the outer ring is negative (see dwg below). Apply either dielectric grease or Vaseline to the terminals. The boot on the back of the socket are oriented so the wiring harness will route straight up from the socket, hiding it under the tail fairing.

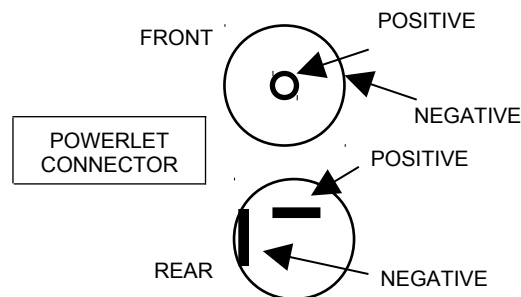

Sport Bike Rearset Kit

PKT-041



STEP #4 – The Powerlet bracket can be configured to be either forward facing or rear facing (see diagrams to the right). Select the direction that best suits your needs.

From the factory the socket comes pre-built on the bracket to be forward facing. The white T connector is intentionally left off to make it easy to convert to a rear facing application.

For forward facing applications snap the red and black wires into the white T connector [A].

For rear facing applications slide the black boot [B] off over the wires and terminals [D]. Remove the brass jam nut and aluminum washer [C]. Remove the socket and re-install the socket from the other side of the bracket. Reassemble the washer, jam nut and rubber boot. Snap the red and black wires into the white T connector [A].

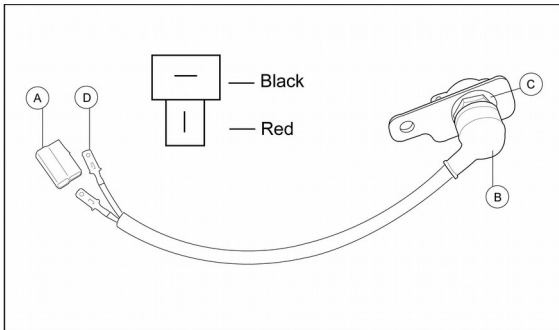

Many times the exhaust is hanging from the rearset and this can be heavier than expected. If your exhaust is hanging from the rearset, loosen both rearset bolts but do not remove them from the tail section sub-frame. By removing only one bolt at a time the weight of the exhaust will hang on the installed bolt. The bracket fits between the sub-frame and rearset and the supplied spacer [E] must be placed between the sub-frame and other rearset mounting point to maintain proper alignment.

Reinstall the rearset with the bracket & spacer sandwiched between the rearset & the frame. Re-use the stock bolts;; tighten to the manufacturers torque specification.

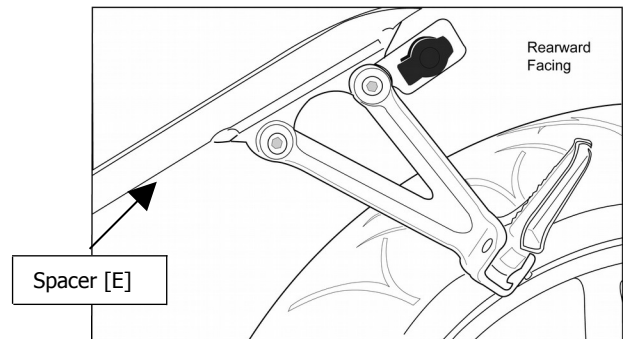
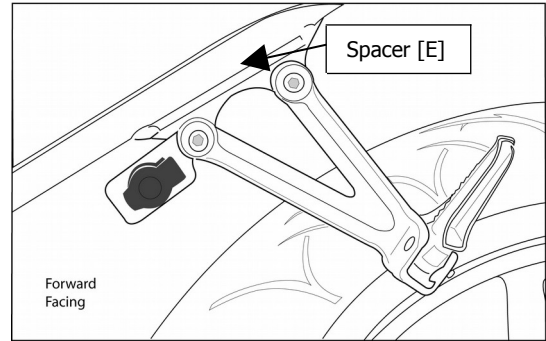

STEP #5 – Apply the remaining ty-wrap to the wiring harness and the frame rail. **Do NOT allow the harness to directly contact the motor or exhaust.**

STEP #6 – Use a voltmeter to check if the polarity is correct. Replace the seat. Enjoy!